

NO DOUBT ABOUT IT,
THIS IS ONE MEAN TRUCK.
IT'S JUST REALLY NICE TO YOU.



No matter how tough the job at hand may be, the International® 7600 is tougher. That's because it's purpose-built from the ground up to handle the most rugged and demanding severe service applications. For starters, it delivers big bore power – up to 430 hp – and superior frame-rail strength. So you can move heavy loads quickly. The International 7600 matches this power with finesse, thanks to the

outstanding maneuverability you get with standard dual steering gears (with 16,000-lb and higher capacity front axles) and up to a 50° wheel cut. All this plus bold good looks, easy serviceability, unmatched reliability and durability, and a refined driver environment. For a truck with such a hard-driving demeanor, the International 7600 couldn't be kinder to owners, drivers and maintainers.



POTENTIAL ADDED VALUE BASED ON 200,000 OWNERSHIP MILES (321,869 KM)

FEATURE

ADDED VALUE

1	Breakaway mirrors	\$900-\$1,200
2	Three-piece hood (front corner replacement)	\$1,000
3	HVAC system self-diagnostics	\$250
4	International Diamond Logic electrical system	\$500
	Increased driver retention and productivity	\$2,500-\$5,500
	TOTAL	\$5,150-\$8,450

1 Two-way breakaway mirrors can withstand up to a 9-mph impact, potentially reducing door and mirror repair costs by \$900-\$1,200 over the life of the vehicle. (Optional heated bright-finish mirrors shown.)

3 Best-in-class HVAC system increases air-conditioning, heating and defrosting flow. Optional air-conditioning includes a self-protection system and self-diagnostics, offering a potential repair savings of up to \$250.



2 The three-piece hood offers a potential repair cost savings up to \$1,000 over a single-piece hood.

4 The International® Diamond Logic™ electrical system brings added brainpower and integration to your application by allowing the engine, transmission, cab and body to communicate with each other.

For added productivity, remote electrical power modules are available along the frame with factory-installed control switches inside the cab.

International® 7600 Popular Feature Options

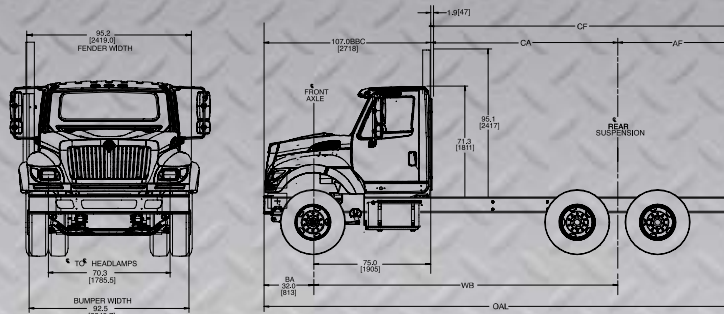

7600 SBA 6x4

Job site maneuverability.

- Up to 50° wheel cut provides outstanding maneuverability.
- Wide-track front axles from 10,000-lb to 20,000-lb (4,536-9,072 kg) capacity for greater maneuverability.
- Standard dual steering gears with 16,000-lb (7,257 kg) and higher front-axle capacity for enhanced maneuverability when fully loaded.

New cab design.

- Standard cab air suspension helps to protect the driver and cab from the shock and vibration associated with severe terrain.
- The swept-back angle and curved design of the windshield and the sloped hood offer a commanding view of the road with outstanding peripheral vision. Also help deflect debris, minimizing glass damage.
- More shoulder room, headroom and belly room raise driver comfort and productivity.
- World-class fit and finish, and improved insulation create a quiet driver environment.
- Standard high-back seats with integrated headrests, easy-to-read gauges and easy-to-use controls ensure that driver needs come first.

Advanced electronics keep your vehicle hard at work.

- The International® Diamond Logic™ electrical system continuously monitors critical vehicle functions, relaying information to the driver to ensure efficient vehicle operation.
- Advanced diagnostics reduce downtime with self-protected intelligent modules that pinpoint electrical problems, saving up to \$500 over the life of your truck.
- The fully programmable system allows for automation of tasks. For example, work lights and equipment can be programmed to shut down after 15 minutes of idle time.

International® 7600 Specifications

Configuration	4x2	6x4
GVWR Range	35K-50K lb	52K-66K lb
BBC	107" (2718 mm)	107" (2718 mm)
Bumper to Axle	32" (813 mm) Set-Forward 40" (1016 mm) Set-Back	32" (813 mm) Set-Forward 40" (1016 mm) Set-Back
Engines	Caterpillar C-10 305-350 hp Caterpillar C-12 335-430 hp Cummins ISM 285-385 hp	Caterpillar C-10 305-350 hp Caterpillar C-12 335-430 hp Cummins ISM 285-385 hp
Transmissions	Manual: 10, 11, 13, 18 Speed Auto: HD4560	Manual: 10, 11, 13, 18 Speed Auto: HD4560
Front Axles	12K, 14K, 16K, 18K, 20K lb	12K, 14K, 16K, 18K, 20K lb
Rear Axles	23K, 26K, 30K, 38K lb	40K, 46K lb
Frame RBM	Single Rail: 1781K-2654K in-lb C-Reinforced: 3806K in-lb	Single Rail: 1781K-2654K in-lb C-Reinforced: 3806K in-lb

For more information on the International 7600, see your International® dealer or visit our web site at www.InternationalDelivers.com.



THE BRILLIANCE OF COMMON SENSE.™

Specifications, descriptions and illustrative material in this literature are as accurate as known at time of publication, but are subject to change without notice. Illustrations may include optional equipment and accessories, and may not include all standard equipment. THE BRILLIANCE OF COMMON SENSE, and Diamond Logic are trademarks of International Truck and Engine Corporation. International and the International Diamond logo are registered trademarks of International Truck and Engine Corporation.